

micPower LCU420, CT-Based Load Monitor

Load Controller with built-in Pump Monitor function

A member of the *micPower* family of Programmable Digital Load Monitors for machinery monitoring, supervising and control. The new *micPower* family of load controllers are based upon the latest advance in 32-bit Microcontroller technology. The *micPower* units are designed to measure true electrical power, either from a motor that is connected directly through the main supply or controlled by a variable frequency inverter. The LCU420 uses a **Current Transformer** for the current measurement. The **Current Transformer** is a reasonable accurate Current Sensor. Other members of the *micPower* family uses Shunt Sensors or Hall Sensors for the Current Measurement. The LCU420A is a Single-Phase Power Measurement Device that measures power on any symmetric load, typically an AC-Motor.

Family features:

- ◆ Single-Phase CT-based design.
- ◆ True Digital Design, High Measurement Bandwidth 0–30 kHz.
- ◆ Measures Power before or after a Variable Frequency Inverter.
- ◆ Measures Inductive Load only.
- ◆ Displays kW[%], kW, HP, RMS Voltage, RMS Current and Power Factor.
- ◆ 0,5 A - 50 A internal transducer. Up to 1000 Amp. with external N/5 transducer.
- ◆ 24V DC Power Supply, electrically isolated.
- ◆ Two Analog Outputs 0(4) - 20(24)mA and 0-10V, electrically isolated.
- ◆ Modbus RTU available on custom demand.
- ◆ IP66 Remote Control. Two wire isolated, short circuit proof interface (power/com).
- ◆ 4-digit Seven Segment Display and 14 LED User Interface.
- ◆ Dimension: 79 x 115 x 45 mm.



The LCU420 is able to display kW[%], kW, HP, RMS voltage, RMS current and Power Factor of the 3 phase load connected. As a true digital design any power related parameter may be calculated. Watch out for a version with Graphic Display to be released at a later point in time. The LCU420 has a built in Current Transformer for Currents up to 50 Amp. For higher current an external Cascade Coupled Current Transformer must be used. An IP 66 Remote Control unit is available.

Synopsis.

The LCU420 measures true power from a symmetrical 3-phase load from the formula:

$$P_T = \frac{1}{T} \int_0^T (V(t) \times I(t)) dt$$

Applications.

The power measurement, which is proportional to machine torque, is very fast down to 10ms (50 Hz) or 8.33ms (60 Hz). This fast measurement makes it possible to react to a blocking condition in order to even stop the machine before it is able to destroy itself. Load Monitoring does **not** protect the motor, it protects the machine or let us say the drive chain. If the machine is not stopped, it is often so strong that it may damage the drive chain. So a Load Monitor gives the operator the possibility to remove the blocking condition before a disaster occur. As a side effect even a bad bearing in the drive train will cause an overload eventually.

The LCU420 has been exclusively developed for **PUMP MONITORING** applications. Many PUMPS are not allowed to run dry from fluid, while the fluid provides coolant for the motor. In this case the PUMP needs to shut down before overheating. A max. limit may be used for protecting jam in the PUMP or shut down in case problems with drive train exist. The max. limit may also serve as a indicator that the PUMP is running allowing a PLC to take action, if the PUMP refuses to start up.



Pump Monitoring Applications:

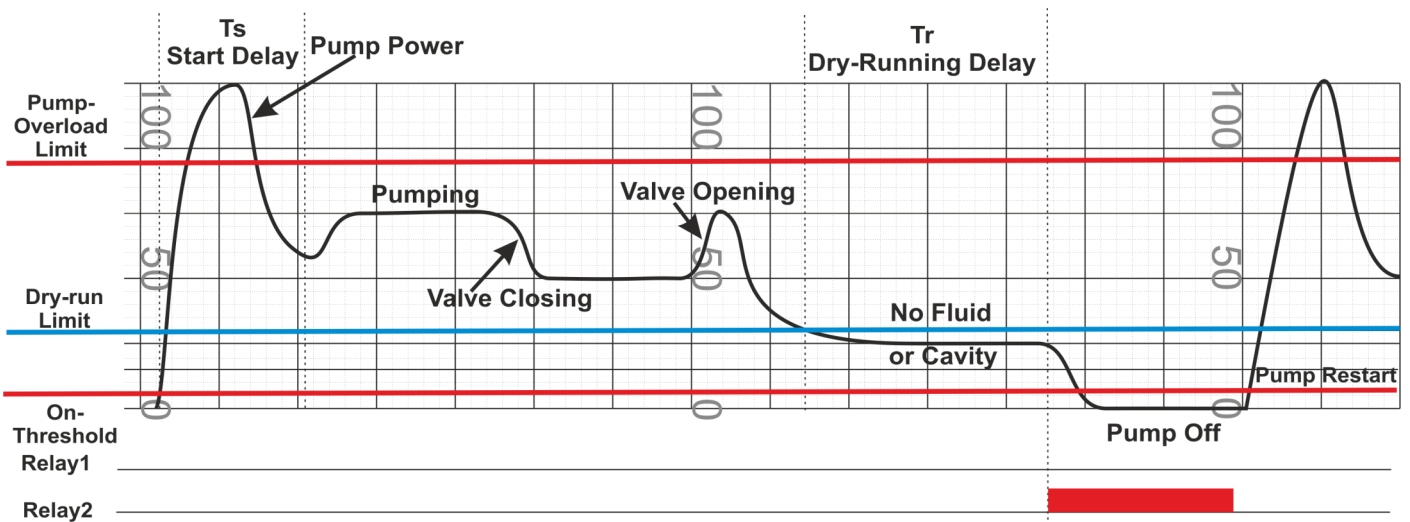

Example Pump Power (Torque) Curve - Exception Limit Mode.

Pump Dry Running Monitoring:

Often the main purpose of a Pump Monitor Application is to keep the Pump from running dry. Many Pumps use the fluid for cooling purpose. If a Pump runs dry for a certain amount of time, it must be shut off to prevent the Pump from overheating. A programmable reaction timer must be set to the maximum time for the Pump may be allowed to running dry. The reaction time must also be long enough for the Pump not to run dry as a result of cavities in the fluid. The LCU420 Limit2 and its associated Reaction Tr2 is used to keep the Pump from dry running.

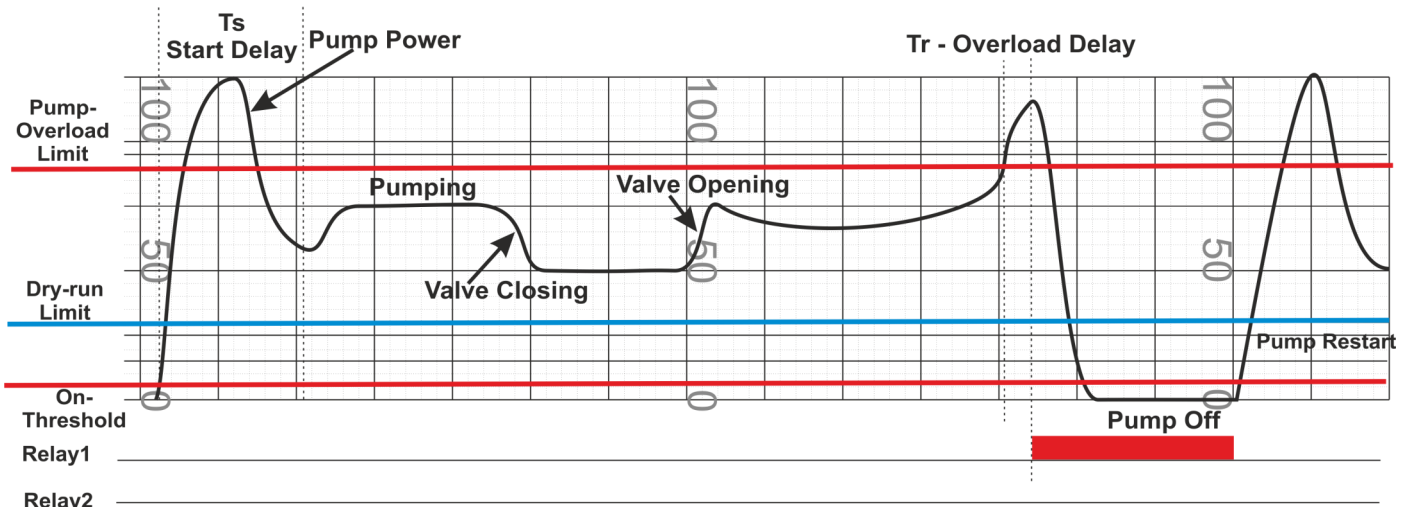

Example Pump Power (Torque) Curve - Exception Limit Generation

Pump Overload Limit:

The parameter number P-04 is used to set the mode of the operation of the Limit1 to be an **Exception Limit** or an **Indication Limit**.

The Limit1 is a maximum limit that either serves as a overload limit or as a Pump running indicator. When the limit serves as a overload limit the LCU420 generates an exception, when the limit1 is exceeded for a certain reaction time Tr1. The overload might be generated from material that is blocking flow through the Pump. The overload condition might as well be cause from a bad bearing or from another fault in the drive mechanism (gear, chain, belt etc.). The limit2 signals an exception, when a alarm is generated and the Pump is supposed to stop. This limit must get reset from the external input S1 (or from the front panel reset-key), same procedure as used with the dry running limit.

Pump Running Indicator:

The parameter number P-04 is used to set the mode of the operation of the Limit1 to be an **Exception Limit** or an **Indication Limit**.

This Operation Mode is used as a remote indication that the Pump is actually running. The relay #1 output may be wired into certain PLC logic takes action, if the Pump is not started. This fault could be caused from blow or switched off fuses to the motor.

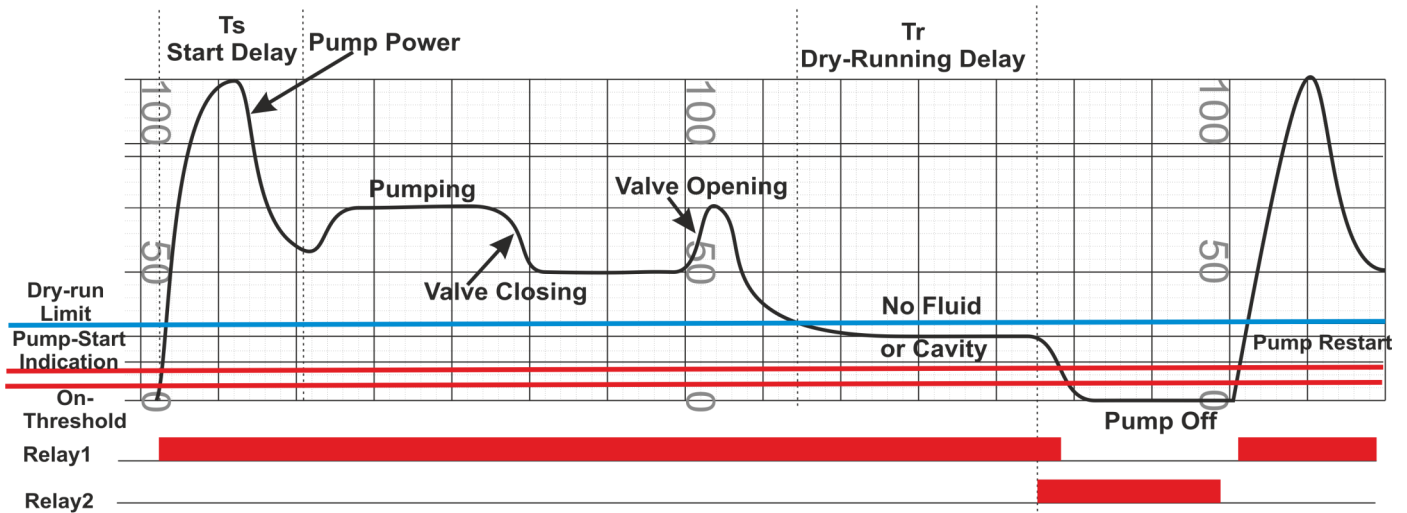

Example Pump Power (Torque) Curve - Indication Limit Mode.

This is the not type of alarm (unlike the Overload Exception) that need to get reset from the external input S1 or from the front panel. In this operating mode the relay #1, is just reset as soon as the Pump Power gets lower than Limit1 (a small hysteresis is added in order not to get relay #1 output to bounce, when the Power is close to the Pump-Start Indication Limit). In this mode the Limit1 has not got any reaction time T_{r1} . No reaction timer is shown on the Front Panel also. The Pump Start Indication limit must be set to a very low like in the range of like 5-10% of the load.

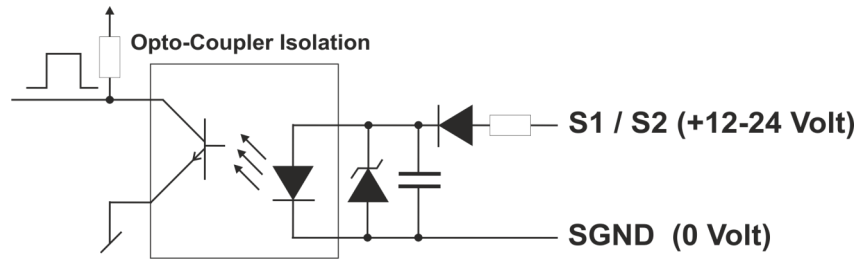

Inputs S1 & S2 (Positive Logic)

Input S1 is used to reset exception alarms. An indication alarm is does not require a reset (see P-04). The input S2 may get used to block alarms from occurring. Alarms may also get reset from the Front Panel Reset key, unless it has been disabled from parameter P-07.

Technical Specifications:

0520

Model:	LCU420
Type:	Load Monitor
Firmware Version:	1.0
Rev:	1.0 HW
Electrical:	
No of Phases:	1
Voltage Input:	3 x 0-500 VAC max.
Current Input:	50 Amp. N/5 Cascaded CT for higher currents
Frequency Range:	0Hz - 30 kHz AC.
Power Factor Range:	0 - 1.
AC Motor Power Range:	0 - 39.837 kW AC, 460V internal CT.
CT Tube Dimension:	11.8 mm, AWG 0000
Supply:	18-36 VDC, Max. 4.0 Watt.
Remote Control:	Yes, 2 wire, power and communication.
Relay Outputs:	240 VAC/5 Amp.
Digital Inputs:	24V Positive Logic.
Analog Output:	Not Present.
Serial Interface:	Not Present.
Mechanical:	
Housing:	Blend PC/ABS self-extinguishing.
Mounting:	35mm Din Rail.
Operating Temperature:	-15 - +50 °C.
Weight:	Approximately 200 gram.
Dimensions:	79 x 115 x 45.0 mm.

CE

Measurement: $P_T = \frac{1}{T} \int_0^T (V(t) \times I(t)) dt$

Functional Ranges:

Mode	Function	Range	Comment
kW%	kW[%]	0–100%	Show kW[%]
Display	kW[%], kW, HP, U, I, PF		Display Function
Limit1	Max. Limit (Overload or Running)	5.0-99.9 (0.0 = Off)	Limit1 (see parameter P-04)
Tr1	Max. Limit Reaction Time	0.01-999.99 seconds	Limit1 Exception Mode Reaction Time
Limit2	Min. Limit (Dry Running)	5-0-99.9 (0.0 = Off)	Limit2
Tr2	Min. Limit Reaction Time	1.0-999.99 seconds	Limit2 Reaction Time
Range[A]	Current Range	0.5-1000 Amp	Current Range
Ts	Start Delay	0.1-999.9 seconds	Start Delay
Param	Parameters Programming	P-00 to P-21	See the list on next page

Programming

The LCU420 is programmed from the use of only four keys located on the front panel. The “Mode” key is used to select programmable parameters. When a parameter is chosen the value may be altered from the use of the arrow keys.

Locked

If the ‘Lock Enable’ P-08 parameter has been enabled then the unit must be unlocked before a variable can be changed. This is done by selecting Locked with the mode key and the hold Both the Arrow Keys down for 5 seconds.

Measurement Ranges

The LCU420 includes an internal CT that measures current up to 50 Amp. Larger currents need an external cascade coupled n/5 Current Transformer.

Peak Detectors

Leave the motor running at normal operation and load. Read the peak detectors by pressing the arrow up/down key when kW or kW [%] is being displayed. If both arrow keys are activated the max power range (100%) in true kW is displayed.

Reset the peak detectors from the reset key.

Wire Diagram:

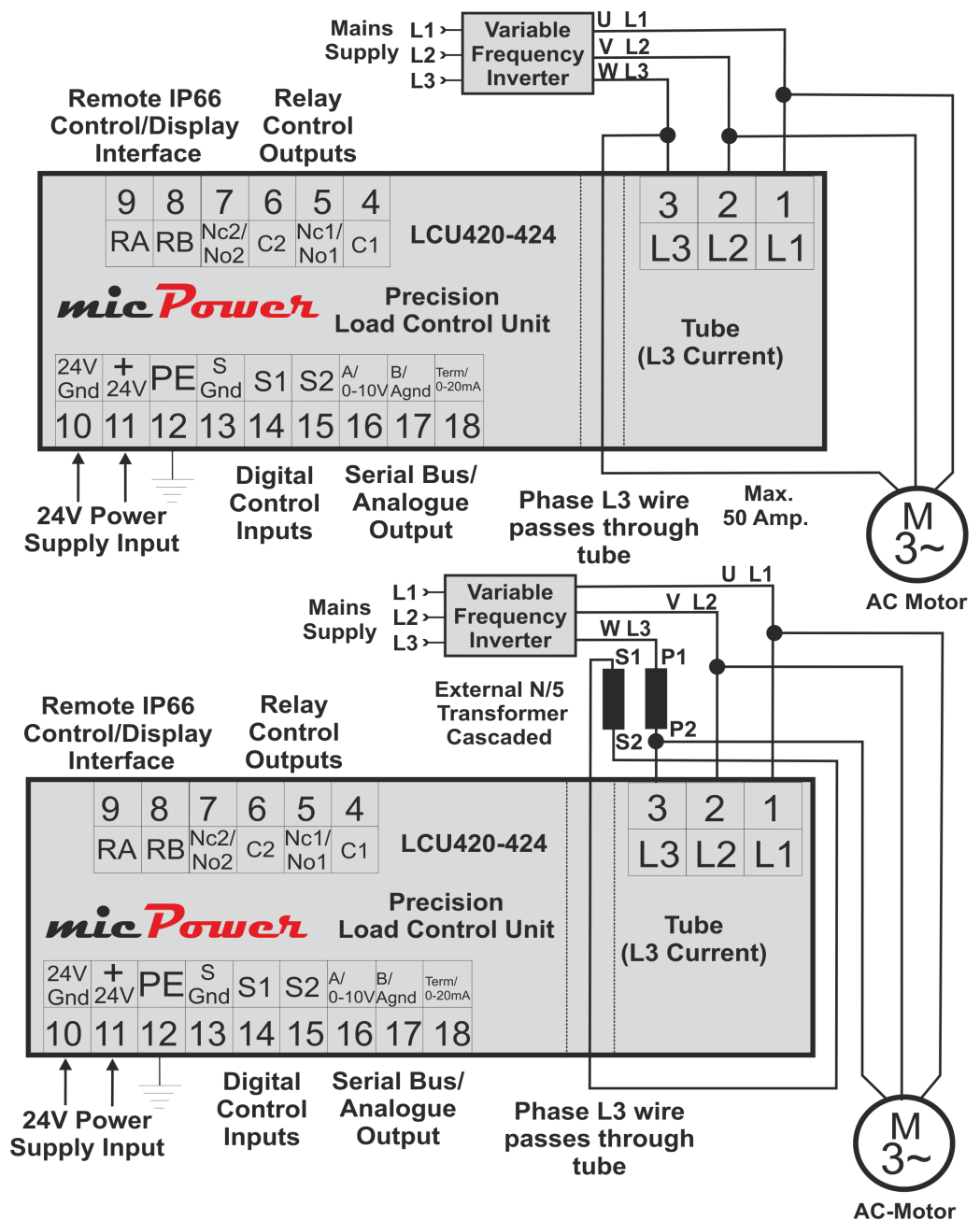

Parameter List:

Mode	Function	Range	Comment
P-00	Nominal Voltage	110V-500 (Default = 400V)	Nominal Voltage Setup
P-01	Relay 1 Function	NC1/NO1 (Default NC1)	Relay 1 polarity
P-02	Relay 2 Function	NC2/NO2 (Default NC2)	Relay 2 polarity
P-03	Averaging Programming	1-20	Measurement Averaging
P-04	Exception/Indication Limit1	OfI/Ind	Exception or Indication Limit1
P-05	On threshold	1.0-25.0 % (Default 3.0%)	Motor Start-Threshold
P-06	Remote Update Enable	On/Off (Default = On)	Enable/Disable Remote Control Update
P-07	Alarm Reset Key Enable	On/Off (Default = On)	Front Panel Reset Key Enable/Disable
P-08	Lock Enable	On/Off (Default = Off)	Enable/Disable Keyboard Lock Function
P-09	Reserved		
P-10	Analog Output Mode	4-20 mA (Default), 0-20 mA or 0-24mA	Analog Current Output Mode Voltage is always 0-10 volt
P-11	Analog P1Max programming	51-100 % (Default = 100%)	Analog P1Max
P-12	Analog P1Min programming	0-49% (Default = 0%)	Analog P1Min
P-13	Analog Polarity Mode	Normal or Inverted (Default = Normal)	Analog Output Polarity
P-14 to P-19	Reserved		
P-20	Show S1 Input State	1.On/1.Off	Show Input S1 state (for testing)
P-21	Show S2 Input State	2.On/2.Off	Show Input S1 state (for testing)

Global Parameter Programming:

Use the mode key to move to the 'Param' Led. The display will show 'Prog'. When the reset key is pushed the parameter number 0 is shown flashing between P-00 and the actual parameter display. The parameter may now get altered from the arrow keys. The mode key is used to advance to the next parameter in the list. If no key is activated for about 30 seconds the display reverse to the default display position: 'kW%'

P-00 = Nominal Voltage

Nominal voltage range. This is necessary to calculate the currently selected Power Range. See table Range[A].

P-01 = Relay 1 Function

Relay #1 polarity normally open or normal close.

P-02 = Relay 2 Function

Relay #2 polarity normally open or normal close.

P-03 = Averaging Programming

Measurement averaging.

P-04 = Exception/Indication Limit1

Limit1 is a exception or indicator limit. No reaction timer is used when the Limit1 is used as an indication limit (motor running).

P-05 = On Threshold

Motor On Threshold.

P-06 = Remote Update Enable

Remote controller enable On/Off.

P-07 = Alarm Reset Key Enable

Enable the reset key from the Front Panel.

P-08 = Lock Function Enable/Disable

Enable and disable of the keyboard lock function. If the lock function is used it must get unlocked before the user is able to modify parameters.

In order to unlock the unit, use the mode key to select "locked" position and then press both arrow keys for about 5 seconds in order to unlock the unit

P-09 = Reserved

P-10 = Analog Output Mode

This Parameter defines the Analog Current Output mode. Options are: 4-20mA, 0 -20mA or 0 -24mA. The voltage output is always 0-10V.

P-11 = Analog P1Max programming

Analog zoom P1Max.

P-12 = Analog P1Min programming

Analog zoom P1Min.

P-13 = Analog Output Polarity Mode

Analog Output Polarity may be Normal or Inverted. Some regulations need Inverted polarity.

P-14 to P-19 = Reserved

P-20 = Show S1 Input State

Show the state of the input the S1. On/Off.

P-21 = Show S2 Input State

Show the state of the input the S2. On/Off.

Power Measurement Range

The Power Measurement Range of the unit is given by the formula:

$$P[W] = \sqrt{3} * U_{nom}[V] * Current-Range[A]$$

P is the power consumption for all 3 phases together. The Phase to Phase Nominal Voltage must be set in Global Parameter #0. The Current Range is programmable from the Front Panel under point Range[A].

The current measurement phase that runs through the unit MUST be the phase that connects to L3 on the Voltage Input Terminal (#3). The direction of the wire is not important as this unit is designed to measure inductive power only. This also mean that it is assumed that the motor cannot work as a generator that sends power back to the main supply.

Notes on the Analog Output

The unit has two simultaneous active analog outputs. A 0-10 Volt output and a current output. The voltage output is fixed but the current output takes 3 different formats: 4-20 mA, 0-20mA or 0-24 mA. The Global Parameter #10 defines which format the current output takes. The default format is 4-20mA. When 4-20 mA is chosen the sensor wire is monitored for wire break. A power consumption of zero is supposed to output 4 mA. The LCU420 would never output a value less than 4mA so when the PLC reads a current close to zero mA, it knows the sensor is not connected or powered on. After the Nominal Voltage Range and the CT Range has been set, then 10 Volt on the voltage output and 20/24mA on the current output will occur at the kilowatt or horse power shown at the right side of the page.

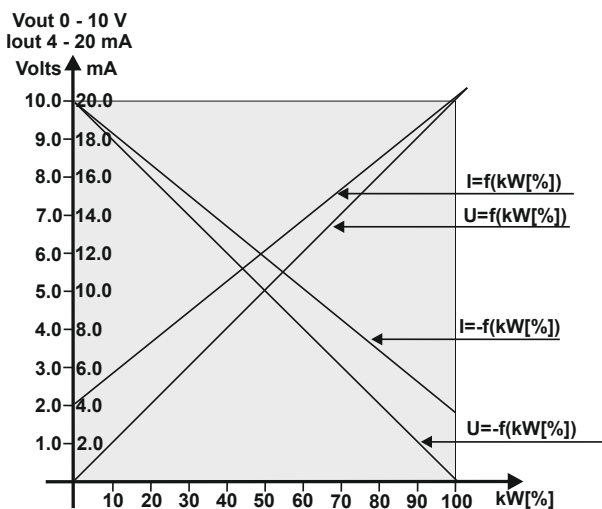

Analog Output 0 - 10Volt and 4-20mA Normal and Inverted

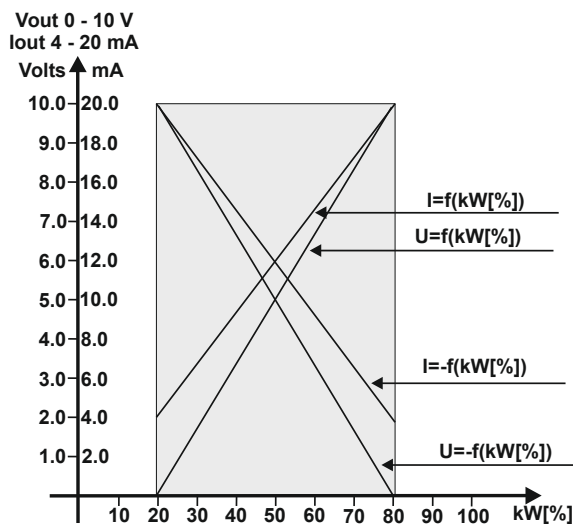

Analog Output 0 - 10Volt and 4-20mA Normal and Inverted
Zoom: P1Min = 20.0 % and P1Max = 80.0 %

Range [A]	kW (460V)	HP (460V)
Int. 0.5	0.398	0.534
Int. 1	0.797	1.068
Int. 2	1.593	2.136
Int. 3	2.390	3.204
Int. 4	3.187	4.272
Int. 5	3.984	5.340
Int. 6	4.780	6.408
Int. 7	5.577	7.476
Int. 8	6.374	8.544
Int. 9	7.171	9.612
Int. 10	7.967	10.68
Int. 11	8.764	11.75
Int. 12	9.561	12.82
Int. 13	10.36	13.88
Int. 14	11.15	14.95
Int. 15	11.95	16.02
Int. 16	12.75	17.09
Int. 17	13.54	18.16
Int. 18	14.34	19.22
Int. 19	15.14	20.29
Int. 20	15.93	21.36
Int. 21	16.73	22.43
Int. 22	17.53	23.50
Int. 23	18.33	24.56
Int. 24	19.13	25.63
Int. 25	19.92	26.70
Int. 26	20.72	27.77
Int. 27	21.51	28.84
Int. 28	22.31	29.90
Int. 29	23.11	30.97
Int. 30	23.90	32.04
Int. 31	24.70	33.11
Int. 32	25.50	34.18
Int. 33	26.29	35.24
Int. 34	27.09	36.31
Int. 35	27.89	37.38
Int. 36	28.62	38.45
Int. 37	29.48	39.52
Int. 38	30.28	40.58
Int. 39	31.07	41.65
Int. 40	31.87	42.72
Int. 41	32.67	43.79
Int. 42	33.46	44.86
Int. 43	34.26	45.92
Int. 44	35.06	46.99
Int. 45	35.85	48.06
Int. 46	36.65	49.13
Int. 47	37.45	50.20
Int. 48	38.24	51.26
Int. 49	39.04	52.33
Int. 50	39.84	53.40
Ext. 30/5	23.90	32.04
Ext. 50/5	39.84	53.40
Ext. 75/5	59.76	80.10
Ext. 100/5	79.67	106.8
Ext. 150/5	119.5	160.2
Ext. 200/5	159.3	213.6
Ext. 250/5	199.2	267.0
Ext. 300/5	239.0	320.4
Ext. 400/5	318.7	427.2
Ext. 500/5	398.4	534.1
Ext. 600/5	478.0	640.8
Ext. 700/5	557.7	747.6
Ext. 800/5	637.4	854.4
Ext. 900/5	717.1	961.2
Ext. 1000/5	796.7	1068

Quick Setup Guide

1. Apply 24 VDC Power to terminals 10 (Gnd) and 11.

The unit powers on and shows its type and version during power on.

2. Unlock the Unit.

Unlock if this function is enabled from parameter #8.

Push the mode key multiple times until the LED 'Locked' is lit and the display shows 'On'. This means that the lock function is now on and you cannot alter any variables. Now hold both arrow keys down for about 5 seconds. After about 5 seconds the display shows 'Off' and the 'Locked' LED starts flashing. Now the unit is open for setup (programming).

3. Set the Current Range.

Use the mode key to go to the point on the Front Plate named Current Range. Now select the immediate current range you think you need. Fine tune later.

4. Set the Nominal Voltage.

Nominal Voltage is one of the seldom programmed variables that may have been set before shipping to the customer.

The nominal voltage is the RMS Phase to Phase voltage. You can change it like this: unlock the unit (2). Use the mode key to move to the point Param on the front plate. Now push reset key once to enter parameter mode. Now the display flashes between P-00 and 460 (nominal voltage). Now the nominal voltage can be increased or decreased from the Arrow Keys. Please note that the setup of these special parameters must be carried out with a certain speed or the displays drops back to normal display mode.

Hint. When Nominal Voltage and Current Range has been set you can display the Power Measurement range like this. Go to the point on the Front Plate named kW or HP. Now push both arrow keys simultaneously and the display shows the Power Range in true kW or HKP.

5. Fine Tune Current Range.

If the unit default operating range is in the 30 – 70% of the selected range. Turn on the motor and select kW% as display mode. When the motor is running normal load it should display like 30 – 70 %. If measurement is too small you should now decrease the Current Range and if the display reading is too large you should increase the Current Range (point 3).

